

Spring-Set Brakes

Fail-Safe Electrically Actuated Friction Brakes

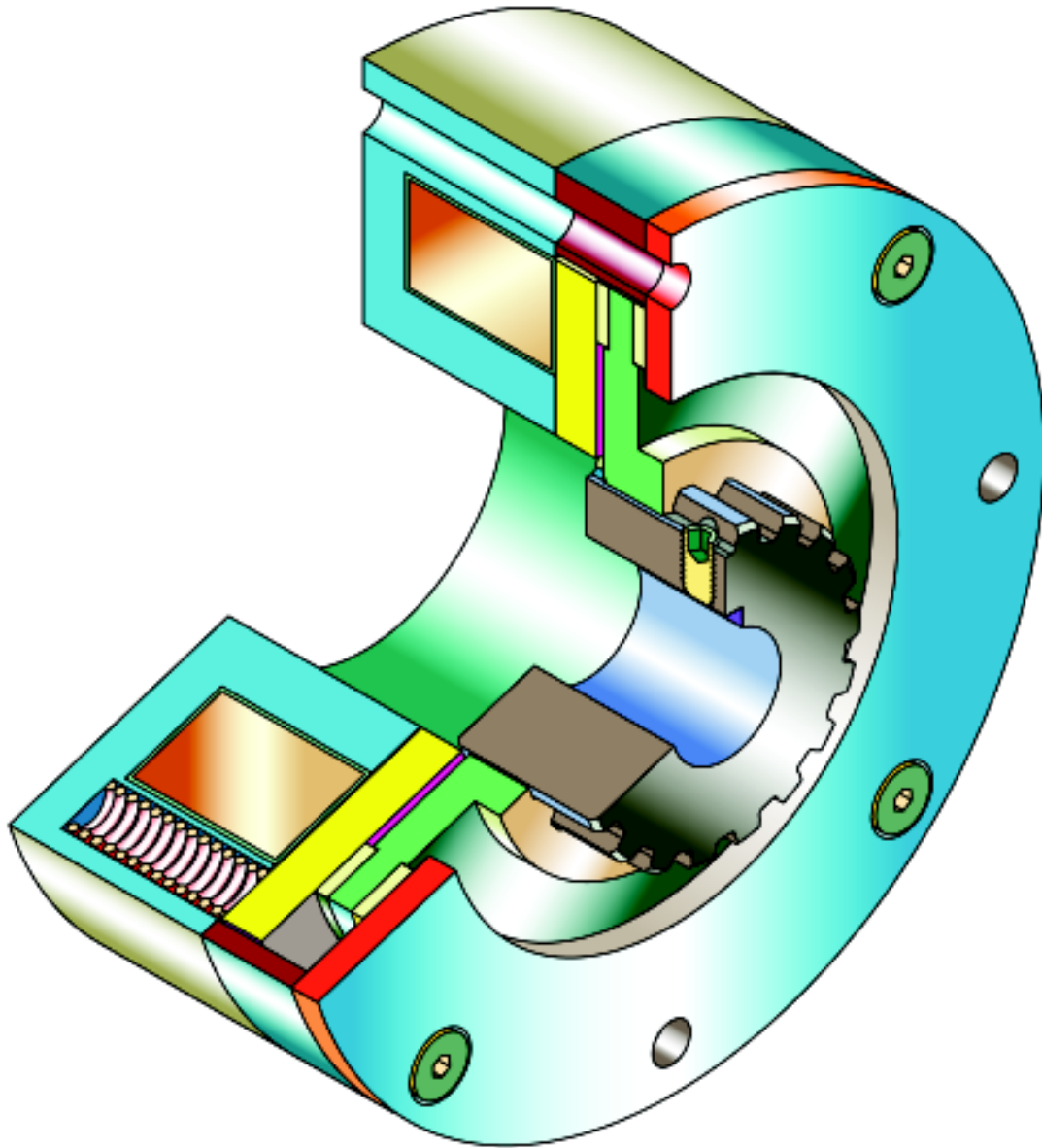

THE MAXITORQ® ADVANTAGE

- Power off design (electrically released)
- Low inertia
- Minimum backlash
- Factory set air-gap needs no adjustment
- Completely covered friction disc
- Excellent torque-to-size ratio
- Reliable repeatability



THE CARLYLE JOHNSON MACHINE COMPANY, L.L.C.

www.cjmco.com

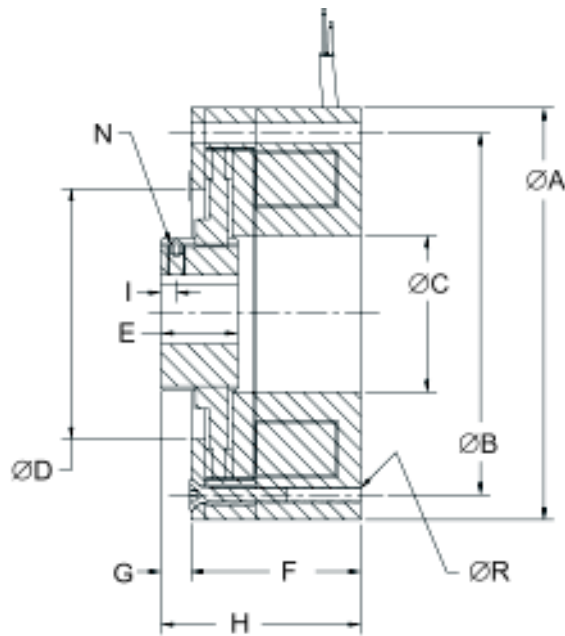
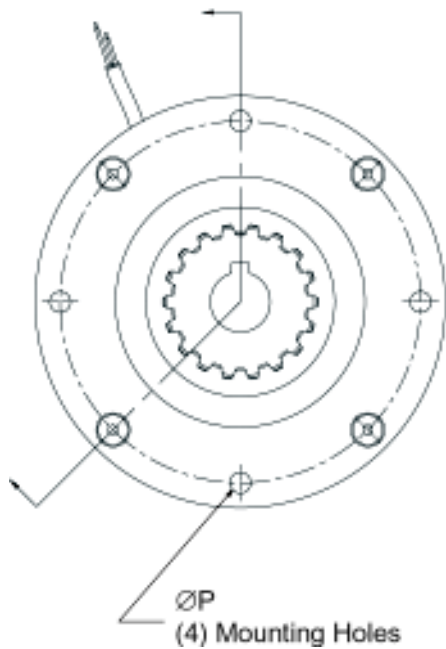

FEATURES / DIMENSIONS

MAXITORQ[®] Model SAB Spring-set Brakes are designed for use as holding brakes or for infrequent emergency stops. Braking torque is applied when electrical power is removed from the brake coil. This can occur intentionally or when there is a power failure. Because of this characteristic, these brakes are frequently referred to as “fail-safe” devices.

Removing power from the brake coil releases compression springs which clamp a friction disc between the brake armature and the end cap, thereby providing braking torque to the shaft where the friction disc is connected. To release the brake, power is applied to the coil. This produces a magnetic field, which pulls the armature away from the friction disc and removes the braking torque. A protective sleeve prevents dirt from entering the friction disc surface when used in a dusty environment.

	Ø A	Ø B	Ø C	Ø D	E	F	G	H	I	N	Ø P	Ø R
SAB-25	2.460	2.125	0.860	1.375	0.600	1.515	0.250	1.765	0.135	6-32	.171 .161	4-40
SAB-35	3.520	3.125	1.375	2.000	0.700	1.595	0.345	1.940	0.150	8-32	.200 .190	6-32
SAB-43	4.270	3.750	1.625	2.600	0.800	1.767	0.365	2.132	0.160	10-32	.223 .213	8-32

Typical applications include medical diagnostic equipment, indexing, parts handling equipment, parking brakes on mobile equipment and holding brakes in servo drives and robotic mechanisms. Standard models offer a range of holding torque from 1 lb-in to 180 lb-in. However, a significant portion of Carlyle Johnson’s production is directed to user-specific requirements, including application of SAB Brakes for frequent, high-energy stops.

Carlyle Johnson has almost 100 years experience in producing high quality clutches, brakes, torque limiters, fail-safe brakes, and power take-off packages. Our clutch knowledge and capability to respond to customer requirements is known throughout the industry. We offer a full-time engineering staff to assist you with new applications and in solving power transmission problems.

SPECIFICATIONS

MODEL	HOLDING TORQUE (lb-in)	RELEASE TIME (sec)		WEIGHT (lbs)		INERTIA (lb-in ²)		COIL VOLTAGE ¹	POWER (watts)		CURRENT (amps)		COIL RESISTANCE (ohms)	
		24 V COIL	90 V COIL	UNIT	HUB	24 V COIL	90 V COIL		24 V COIL	90 V COIL	24 V COIL	90 V COIL		
SAB-25	17	0.032	0.035	1.20	0.06	0.03	0.004	24 or 90	12	11	0.50	0.13	48	704
SAB-35	88	0.050	0.061	2.60	0.20	0.16	0.045		20	20	0.85	0.23	28	398
SAB-43	180	0.070	0.083	4.36	0.25	0.48	0.063		27	27	1.13	0.29	21	306

Notes:
 1. Other voltages available.
 2. Various standard and metric bore sizes are available.



291 Boston Turnpike - P O Box 9546 - Bolton, Connecticut 06043-9546
 (860) 643-1531 • FAX (860) 646-2645 • TOLL FREE (888) 629-4867 • www.cjmco.com